

ARB COMBINATION WINCH / NON WINCH BULL BAR TO SUIT MITSUBISHI PAJERO “NP” 2003 ONWARD .

FITTING KIT No:- 6171798
BULL BAR Product No:- 3434060

WARNING :-

FOR VEHICLES EQUIPPED WITH SRS AIRBAG

WHEN INSTALLED IN ACCORDANCE WITH THESE INSTRUCTIONS, THE FRONT PROTECTION BAR DOES NOT AFFECT OPERATION OF THE SRS AIRBAG.

TAKE NOTE OF THE FOLLOWING:

- THIS PRODUCT MUST BE INSTALLED EXACTLY AS PER THESE INSTRUCTIONS USING ONLY THE HARDWARE SUPPLIED.
- DO NOT USE THIS PRODUCT FOR ANY VEHICLE MAKE OR MODEL, OTHER THAN THOSE SPECIFIED BY ARB.
- DO NOT REMOVE LABELS FROM THIS BULL BAR.

THIS PRODUCT OR ITS FIXING MUST NOT BE MODIFIED IN ANY WAY.

TOOLS REQUIRED TO FIT THIS BULL BAR: -

METRIC SPANNER & SOCKET SET , 3/8” SOCKET , LARGE “G” CLAMP , ELECTRIC DRILL , METRIC DRILL BITS :- 6.5 mm , 10.5 mm and 12.5 mm , SMALL ANGLE GRINDER OR HEAVY DUTY WIRE CUTTERS , SHARP KNIFE OR A HACKSAW BLADE , PHILIPS HEAD SCREW DRIVER , FLAT BLADED SCREW DRIVERS AND A METRIC TAPE MEASURE .

APPLICATION	PART No	QTY	DESCRIPTION
IMPACT ABSORBER ASSY TO CHASSIS	3756553 LH	1	IMPACT ABSORBER ASSY LH
	3756553 RH	1	IMPACT ABSORBER ASSY RH
	3756557L/R	1 & 1	BRACKET CHASSIS SUPPORT INBOARD
	3756556L/R	1 & 1	BRACKET CHASSIS SUPPORT OUTBOARD
	6151255	6	BOLT M12X40
	4581050	6	WASHER SPRING M12
	4581049	6	WASHER FLAT M12
	615 1305	6	NUT CAGED M12
	319 9848	6	PLATE M12 CAGE NUT
	6151357	10	BOLT M10 X 30 SEMS
	6151321	10	M10 FLANGE NUT
IMPACT ABSORBER TO BULL BAR	6151255	6	BOLT M12 X 40
	4581050	6	WASHER SPRING M12
	4581007	6	WASHER FLAT M12
CONTROL BOX BRACKET TO BULL BAR	375 6209	1	CONTROL BOX BRACKET
	615 1021	2	M8 x 20 mm BOLT
	458 1044	2	M8 FLAT WASHER
	615 1132	2	M8 FLANGE NUT
NUMBER PLATE TO WINCH BAR	375 1451	1	NUMBER PLATE BRACKET
	615 1017	4	M6 x 16 mm BOLT
	615 1046	4	M6 FLAT WASHER
	615 1128	4	M6 FLANGE NUT
NUMBER PLATE TO NON WINCH BAR	615 1017	2	M6 x 16 mm BOLT
	615 1046	2	M6 FLAT WASHER
	615 1128	2	M6 FLANGE NUT
PLASTIC GUARD TRIM TO BULL BAR WING	615 1180	2	M6 x 20 mm BOLT
	615 1046	2	M6 FLAT WASHER
	615 1128	2	M6 FLANGE NUT
LOCKING BOLT HARDWARE	615 1357	2	BOLT SEMS M10 X 30
	615 1321	2	NUT FLANGED M10
WINCH COVER FITMENT	652 1031	1	WINCH COVER
	619 1001	1	WINCH COVER EXTRUSION
	615 1256	2	M6 BUTTON HEAD SCREW
	615 1046	2	M6 WASHER
	615 1128	2	M6 FLANGE NUT
MISC	350 0170	1	BUFFER KIT
	350 0080	1	ARB INDICATOR KIT
	180 302	8	BLACK CABLE TIES
	458 1040	4	3/8" FLAT WASHER (ROLLER FAIR LEAD)
	615 1074	2	3/8" x 1 3/4" BOLT (ROLLER FAIR LEAD)

ASSEMBLY SEQUENCE FOR ARB BULL BAR.



1. To remove the bumper bar from the vehicle , remove the 3 plastic plugs that hold the plastic guard liner to the bumper bar on each side using a small flat bladed screw driver .

The head of the plug is levered up so the body of the plug can be removed from the hole . Remove the four plugs from the lower wheel arch area on both sides .

There are a further four plugs that hold the bumper bar to the vehicle in the bottom (central) edge of the bumper bar .To access these the lower stone guard needs to be removed , four bolts hold it into position .



2. Using a Philips head screw driver remove the vertical screw on the out board top edge of the bumper bar (this screw and following bolt are accessed from the wheel arch area) . Using a 10mm socket remove the horizontal bolt , as shown in the photo .

This is done on both sides of the vehicle.

In the lower section of the bumper bar, remove the two M10 bolts that hold the bridging bracket between the guard liner and bumper bar.

These brackets are not re-used when the bull bar is fitted.



3. With all of the plastic plugs, two screws and two bolts removed from the lower bumper bar , the grille and grille cover must be removed. There are three plastic plugs that hold the cover in place, remove these as previously described above.

Once the cover is removed the grille can be taken out, this is done by pushing the grey coloured tags in with a small flat bladed screw driver, a small amount of pressure whilst doing this will release the top of the grille from its mounts .

The bottom of the grille is retained with three push in type plugs .With a small amount of pressure pull the grille from its mounts , with the grille removed a further three M10 bolts holding the bumper are accessible . Remove the bolts and with assistance the bumper can now be removed from the vehicle. Remove the number plate from the bumper bar.



- The three bolts that hold the washer bottle need to be removed to provide clear access to the chassis.

Un-clip the electrical plug from the wheel arch area.

With assistance, hold the impact absorber into position and place the smaller (inboard) chassis bracket into position as shown. Using the M10 hardware supplied assemble finger tight only at this stage.

The larger (out board) bracket is also held in position and bolted up . A “G”clamp will need to be used to hold both brackets firmly against the chassis.

ENSURE THE IMPACT ABSORBER IS LEVEL AND SITTING IN AN UPRIGHT POSITION.

NOTE THE RIGHT HAND SIDE IMPACT ABSORBER IS SHOWN IN THIS PHOTO.



- The inboard bracket is drilled using a 12.5mm drill bit thru to the chassis using the hole in the inboard bracket as a guide.

With this done, repeat this on the out board bracket using the two holes in bracket as a drilling template.



Warning: Drilling operations can result in flying metal debris, safety glasses should be worn.

- Fit 6 x M12 caged nuts to extension plates.

Hint: Load one flange of the cage into position and using a screwdriver depress the other flange so it loads into the slot.



Using 6 x M12 X 40 bolt and washer sets and cage nuts on extension arms inserted up through a hole in chassis as shown, bolt the plates in position. (Note that the extension arms will need to be pre bent to allow the cage nuts to align with the drilled bolt holes and it is advisable to do the hole furthest from the chassis entry hole first.)

Repeat steps 4 - 6 on the LHS of the vehicle .

Confirm the measurement between the impact absorber uprights is larger than 800mm to ensure the bull bar will fit onto the vehicle , then tighten all of the bolts on the impact absorber .

The remaining hole in the impact absorber lower flange can now be drilled using a Dia 10.5 drill bit and pinned using a M10 x 30 SEMS and M10 flange nut fed inside the vehicle cross member



7. Drill Dia 10.5 pinning hole in lower flange of mount bracket into the vehicle crossmember



Warning: Drilling operations can result in flying metal debris, safety glasses should be worn.



8. Fit M10 SEMS bolt and load flange nut from inside cross member then do up tight.



9. With the out board bracket in position and bolted securely (as shown) re-clip the electrical loom connector . The flange on the top of the bracket is to house the connector and snaps into place .

Re-fit the rest of the loom clips into there original holes in the inner wheel arch area .

ENSURE ALL OF THE BOLTS ON BOTH SIDES ARE TIGHT .

Bend away cage nut extension plates so they are not protruding out from the chassis.



When fitting winch only :-

- Place the bull bar down on a blanket to avoid scratches . Bolt the control box bracket to the bull bar with the flat surface of the bracket facing towards the front of the bar, using the M8 x 20 mm bolts and hardware.

Fit the control box to the bull bar using the nuts supplied with the control box.

The turn signal kit and buffer kit can be installed into the bull bar at this stage also.

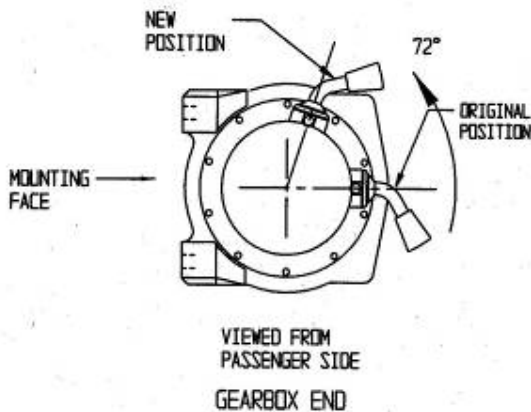

- To place the winch clutch handle in a convenient location the winch gearbox must be rotated 2 hole spacings , 72 degrees , in an anti-clockwise direction when viewed from the gearbox end . Place the winch on its end and remove all gearbox bolts .

Gently raise the gearbox just enough to rotate it as shown . Do not completely remove the gearbox as this will damage the gasket . Refit all of the bolts and tighten.

NOTE :- Take care not to lift the assembly more than a couple of millimetres while rotating to the desired position to avoid unmeshing the gears.

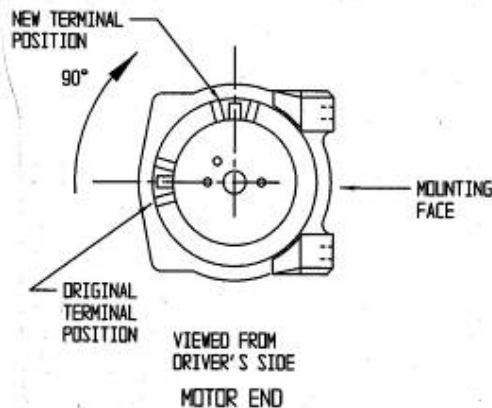

- To place the winch motor in the correct location the winch motor must be rotated 90 degrees, in a clockwise direction when viewed from the motor end.

Place the winch on its end and remove the 2 motor retaining bolts.

Gently raise the motor just enough to rotate it . Do not completely remove the motor as this will damage the gasket. Refit all of the bolts and tighten.

NOTE :- Take care not to lift the assembly more than a couple of millimetres while rotating to the desired position to avoid unmeshing the gears.

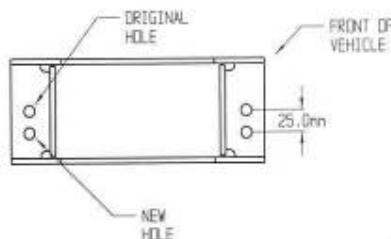

WINCH BAR ONLY

- The roller fair lead must be drilled prior to fitment, it can then be assembled into the front of the bull bar along with the winch as detailed in step 11.

Using a 13.0 mm drill bit drill two holes as shown in the adjacent photo.

The roller fair lead can then be fitted into the bull bar.



14. With the roller fair lead previously in position, lift the winch into position and bolt into place using the 3/8" hardware supplied with the winch, bolt securely in place.

NOTE :- the gear box is on the left hand side . The winch cable spools from the bottom of the winch drum.

Wire the winch as per the winch instructions. Using the cable ties, tie the wiring back to the rear edge of the bull bar using the holes in the flange . Ensure the wiring is clear of the winch drum & cable etc and does not rub on any hot , moving parts or sharp edges .

Failure to do so could result in damage to the electrical system.



15. Feed the winch cable through the roller fair lead .

Mount the hook to the end of the cable as shown using the hardware supplied in the winch kit .



If winch not fitted,

16. Attach the number plate directly to the bull bar front face using the M6 hardware supplied.

If the bull bar is fitted with a winch

17. Use the number plate bracket supplied and fit to the bull bar as shown with the M6 hardware supplied.



18. Where a **WINCH IS NOT FITTED** :- Wrap the rubber extrusion around winch cover.

Place washers over the winch cover fixing holes located on the top middle face of the bull bar.

Place the winch cover on top of the bull bar in line with the mount holes.

Bolt together using the M6 button head stainless steel screws and M6 nuts.



19. With assistance lift the bull bar into position and slide it over the two impact absorbers. Once in position bolt the bull bar in the 6 places using the M12 x 40 bolts and washer sets supplied.

Adjust the bull bar on the vehicle until a uniform gap is achieved to the grill & headlamp and guards. Once happy with the position of the bull bar tighten all of the bolts.

The bull bar is then drilled and pinned in its final position. Using a dia 10.5 drill bit, drill & pin the bull bar using the M10 hardware supplied as shown in the attached photo.

The original lower stone shield can now be bolted back into its original position using the original fasteners.



Warning: Drilling operations can result in flying metal debris, safety glasses should be worn.



20. Re-Connect the turn signal harness on both sides of the vehicle .Connect the winch cables to the vehicle electrical system and cable tie to ensure cables are well clear of any hot, moving parts or sharp edges.

The turn signal is supplied with a loom kit, this is plugged in to the turn signal one end and spliced into the vehicles original wiring at the other end.

Trim the plastic inner guard liner with a sharp knife or hacksaw blade .Using the wing profile as a template trim the guard by aligning the liner with the bull bar wing edge and the lowest part of the wing. Using the hole in the wing as a guide, drill a 6 mm hole and secure the guard liner to the wing with the M6 hardware supplied.

Insert the original plastic plugs that were removed from the liner into the remaining holes in the wheel arch area.

Ensure all bolts are tight, and all wiring and turn signal lamps are functioning correctly.

PRODUCT FITTED TO VEHICLE

